

"

"

"

"

1 **1**

2 **17**

3 **33**

4 “ ” **39**

5 **42**

6 **46**

7 64

8 77

9 84

1

1.1

1.1.1

1.1.2

1.1.3

1.1.4

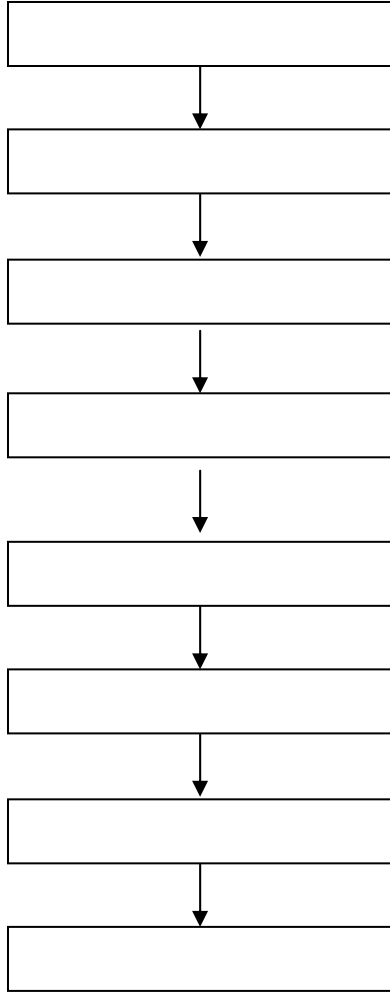

1.1-1

1.2

1.2.1

-
-
-
-

1.2.2

1.2-1

1.2.3

" "

1.2.4

1.2.5

1.2.6

o

“ ”

“ ”

1.2.7

1.2.8

1.2.9

#

#

1.3

1.3.1

1.3.2

1.3.3

◦

1.3.4

1.3.5

1.3.6

1.3.7

1.3.8

1.3.9

2

2.1

2.2

2.3

2.3.1

2.3.2

2.3.3

2.3.4

2.3.5

2.3.6

2.3.7

2.3.8

(3)

(4)

(5)

(6)

(7)

(8)

(9)

(10)

2.3.9

(1)

(2)

“ ”

(3)

(4)

(5)

(6)

(7)

(8)

(9)

(10)

(11)

(12)

2.3.10

(1)

(2)

(3)

2.3.11

2.3.12

2.3.13

2.3.14

2.3.15

2.3.16

2.3.17

2.4

2.4-1

2.4-2

2.5

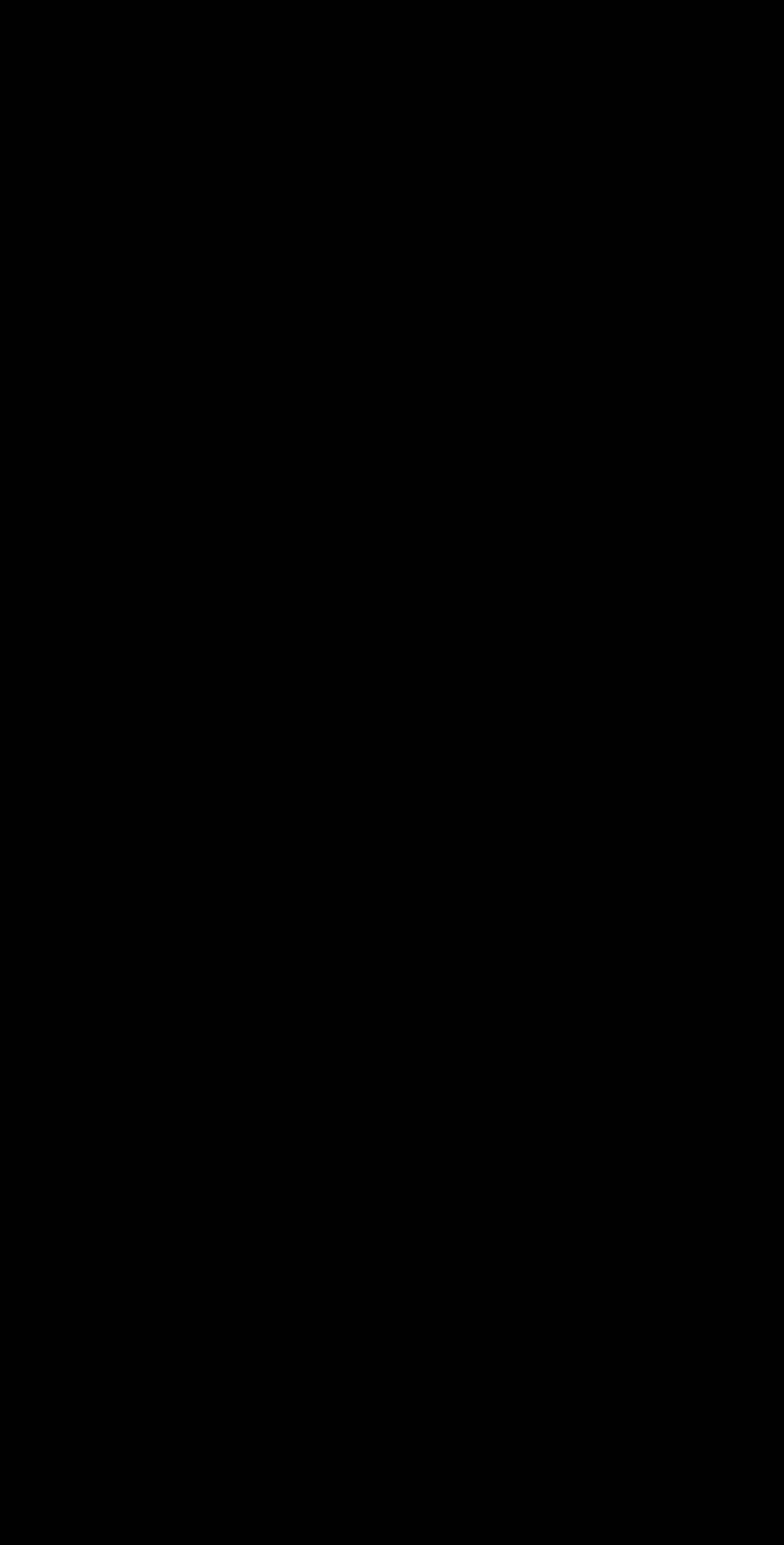

[

2.6

3

3.1

3.1.1

3.1.2

3.1.3

21

3.1.4

3.1.5

3.2

3.2.1

3.2.2

3.3

3.3.2

4 “ ”

4.1 “ ”

4.1.1 “ ”

“ [2010] 428 ”

2011 1

7 “ [2011] 1 ”

4.1.2 “ ”

4.1.3 “ ”

"

"

4.2

4.2.1

4.2.2

4.2.3

4.2.4

4.2.5

4.2.6

4.2.7

4.2.8

4.3

5

5.1

5.1.1

5.1-1

5.1.2

5.2

5.2-1

5.2-2

5.3

5.3.1

5.3.2

5.4

6.2

6.2.1

6.2.2

6.2.3

6.2-1

6.2-1

6.2.4

6.2.5

6.3

6.3.1

6.3.4

6.3.5

6.4

6.4.1

6.4.2

◦

6.4.3

6.4-1

6.4-1

		◦ ◦	

6.4.4

6.4.5

6.5

6.5.1

6.5.2

6.5.3

6.5-1

6.5-1

6.5.4

6.5.5

6.6

6.6.1

6.6.2

6.6.3

6.6-1

6.6-1

4				

6.6.4

6.6.5

6.7

6.7.1

6.7.2

2

2 WQX70-120-45 70m³/h 120m 380V

6.7.3

6.7-1

6.7-1

1				
2				
3				
4				

6.7.4

1

2

3

4

5

6

6.8.3

6.8-2

6.8-2

	"	"	

6.8.4

6.8.5

6.9

6.9.1

6.9.2

6.9.3

6.9-1

6.9-1

6.9.4

6.9.5

6.10

6.10.1

6.10.2

6.10.3

6.10.4

6.11

6.11.1

6.11.2

6.11.3

6.11.4

6.12

7.1

7.1.1

7.1.2

7.1-1

7.2

7.2.1

7.2-1

7.3.2

7.4

7.4.1

7.4-1

7.4.2

7.5

7.5.1

7.5-1

7.5.2

7.6

7.6.1

7.6-1

7.6.2

$$T = A \cdot A \cdot A = B + B \quad X + X \quad X + X \quad + X$$

$$= \quad + \quad + \quad + \quad + \quad + \quad + \quad + \quad + \quad +$$

$$I_{\phi} \quad i = \sum_{X_i \in kj} \frac{\quad}{nj -}$$

ϕ

$I \quad I$

I I I I

I I

I I I

I I I I I I I I I I I I

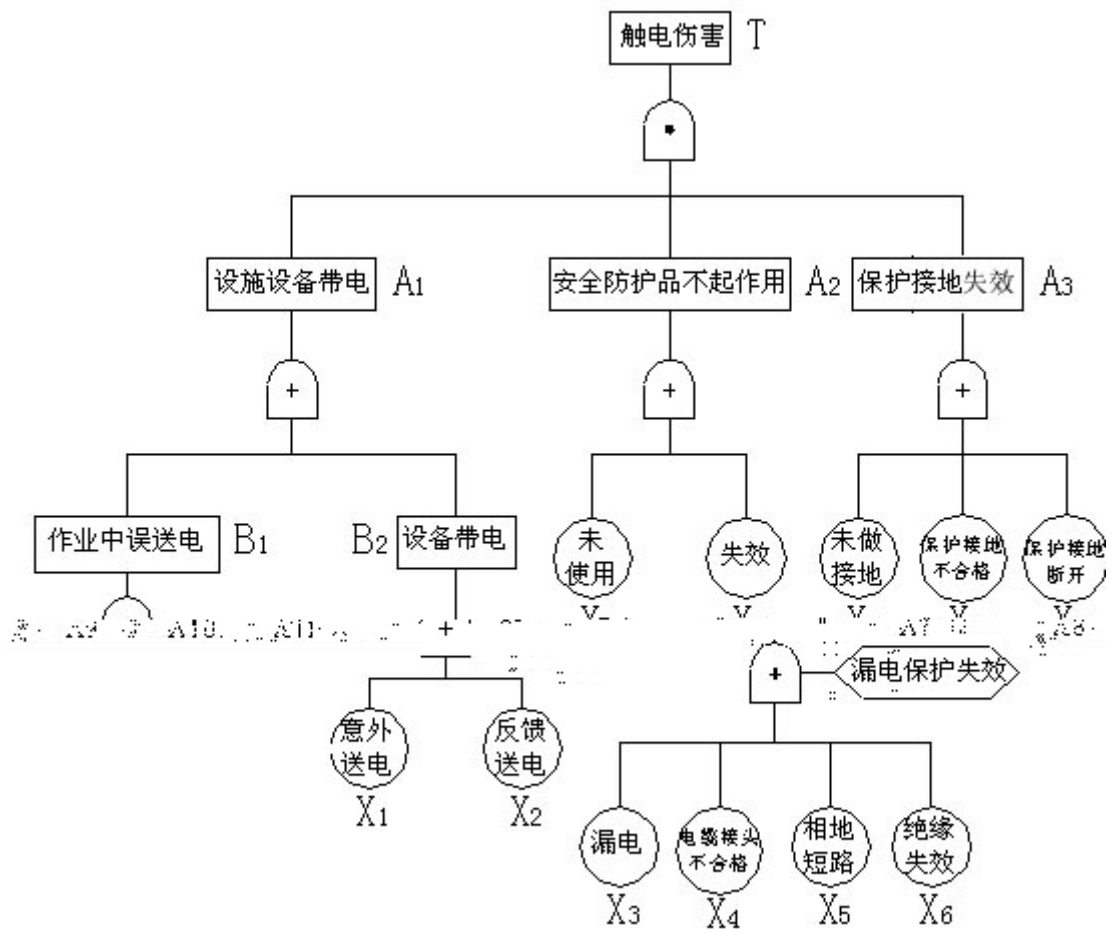

7.6-1

7.6.3

7.7

7.7.1

7.7.2

7.7-1

7.7.3

$$T = A \cdot A$$

$$= \quad + B \cdot \quad + X \quad + X$$

$$= \quad + \quad + \quad + \quad + \quad \cdot \quad + \quad +$$

$$\phi = \phi = \phi > \phi = \phi = \phi = \phi = \phi$$

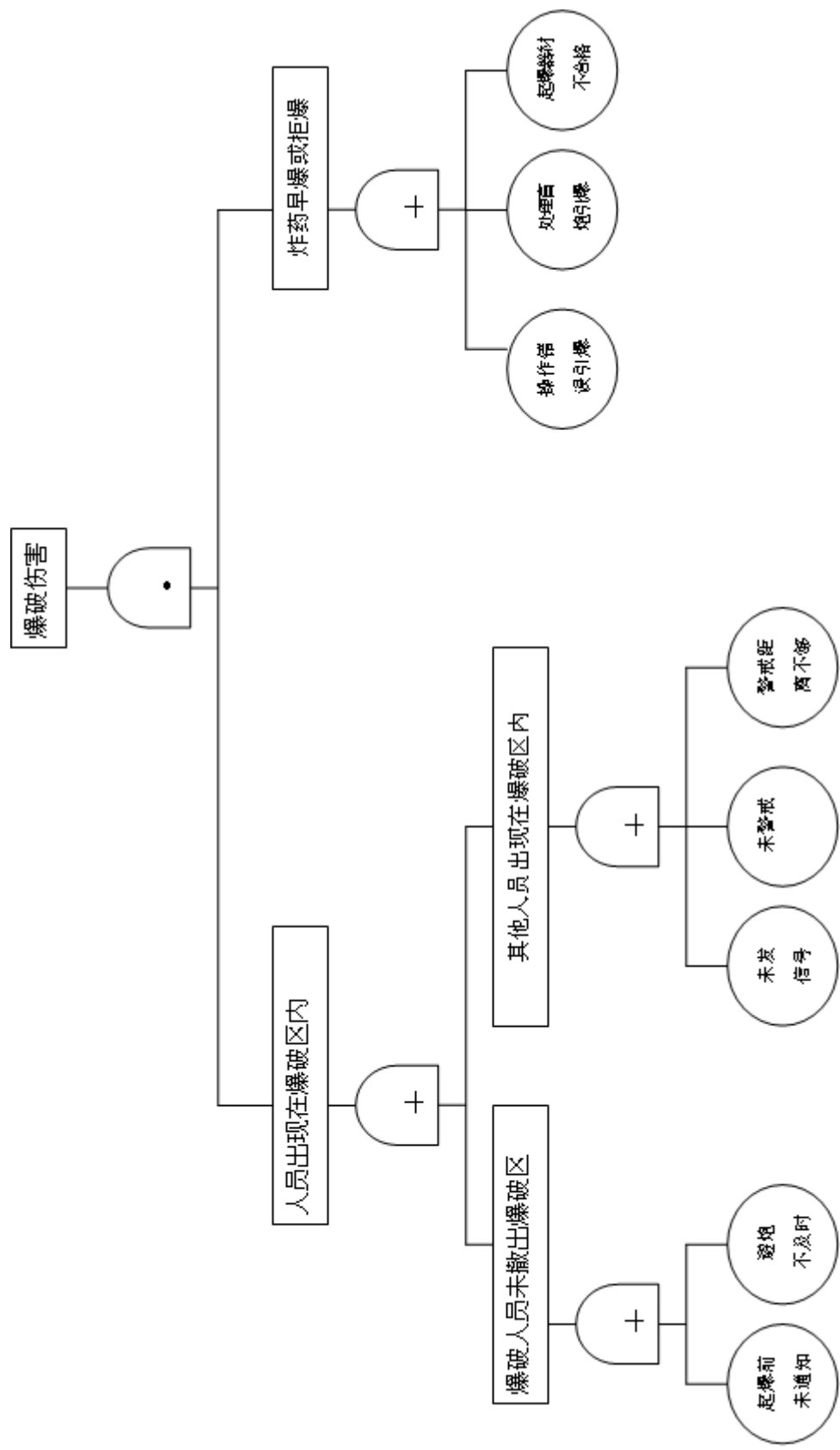

7.7-1

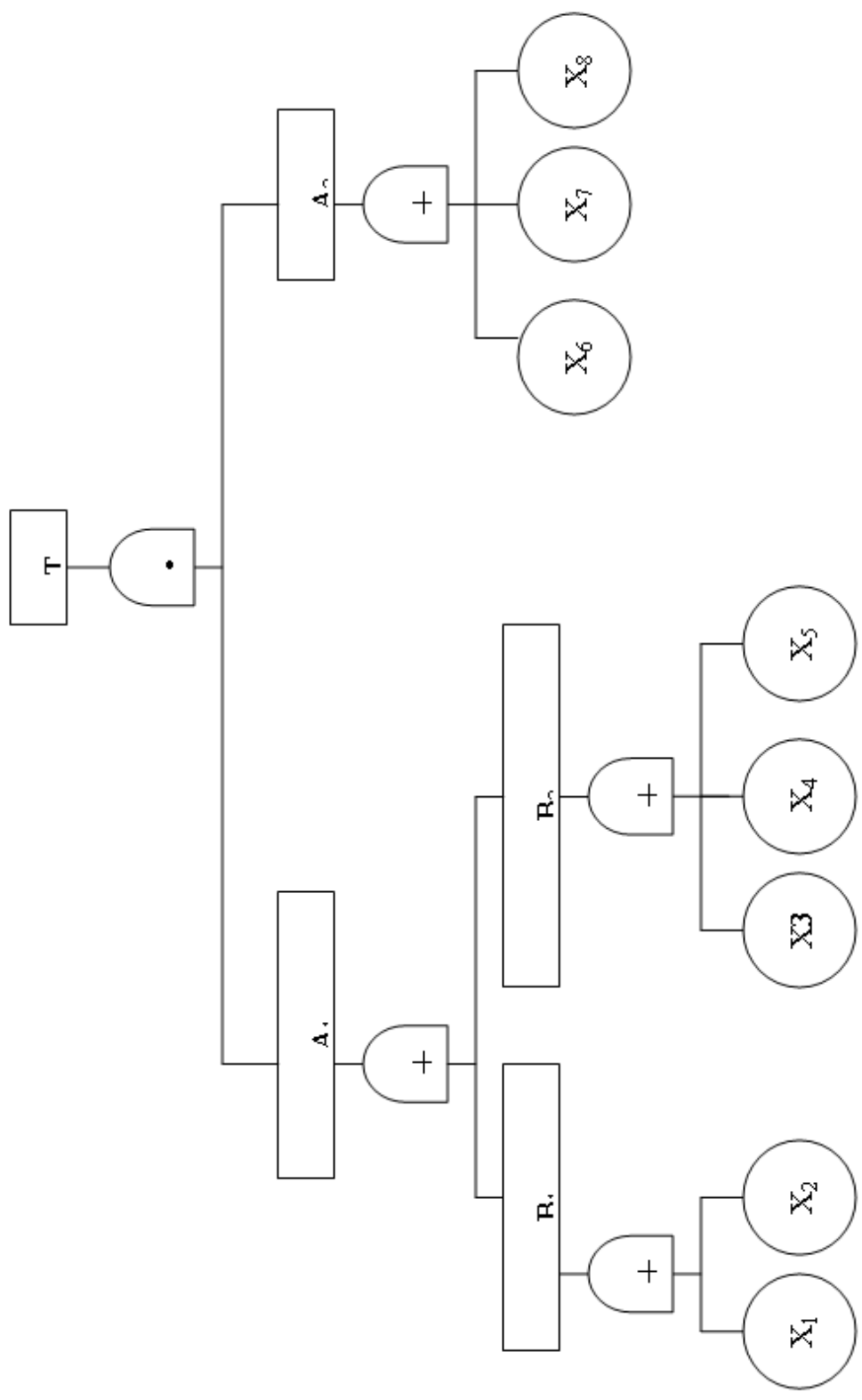

8

8.1

8.2

8.3.2

8.3.3

8.3.4

8.3.5

8.3.6

8.3.7

8.3.8

8.3.9

8.3.10

9

9.1

9.2

9.3
